

FREQUENCY AND TIMING SYSTEM FOR THE
CONSOLIDATED DSN AND STDN TRACKING NETWORK

R. C. Coffin, D. E. Johnson, and P. F. Kuhnle

Jet Propulsion Laboratory*
California Institute of Technology
Pasadena, California

ABSTRACT

For NASA, JPL is presently in the planning phase of consolidating the existing Deep Space Network (DSN) and colocated Goddard Spaceflight Tracking and Data Network (STDN) stations into a multiple antenna array.

Each site will include a Signal Processing Center (SPC) centered in an array of four or five antennas each located within approximately 300 to 800 meters of the SPC. A central Frequency and Timing System (FTS) located in the SPC will contain reference frequency, timing and time code generation, and distribution equipment for both the SPC and each antenna with its associated front end antenna control building.

The reference frequency distribution and clock equipment will be driven by a Hydrogen Maser as the prime frequency standard with Cesium Beam Frequency Standard as the secondary.

This paper will present the proposed equipment configuration and preliminary performance specifications for the above Frequency and Timing System.

INTRODUCTION

The advent of the Tracking Data Relay Satellite System (TDRSS) will herald major changes to NASA's ground-based tracking networks. An offshoot of these changes, which will be discussed in more detail below, is

* This paper presents the results of one phase of research carried out at the Jet Propulsion Laboratory, California Institute of Technology, under Contract No. NAS 7-100, sponsored by the National Aeronautics and Space Administration.

the consolidation of JPL's globally-distributed Deep Space Network with colocated elements of GSFC's Ground Spaceflight Tracking Data Network (GSTDN). In conjunction with these modifications to the ground tracking networks, there will be requisite changes to the Frequency and Timing Subsystem (FTS) which provides references for the telemetry, command, and tracking applications of these stations.

The schedule of modification to the Ground Tracking Networks is driven primarily by spacecraft events such as launches and planetary encounters, and by funding availability. Present planning indicates that major implementation activities will occur in the 1983-1985 time period. Consequently the state of the design is still functional at this time. Early assessments of the Frequency and Timing System requirements have been made and a high-level system functional design has evolved. Additionally, the subsystem functional requirements have been tentatively established and are currently being revised. The purpose of this paper is to introduce the Consolidated Space Communication Network to the frequency and timing community and to show the present thinking at Goddard and JPL about the design of the Frequency and Timing System to support that network.

NETWORKS CONSOLIDATION PROGRAM OVERVIEW

Decisions were made by NASA in 1979 which will, by 1985, result in the merger of the colocated tracking facilities of the Ground Spaceflight Tracking and Data Network (GSTDN) and the Deep Space Network (DSN). This Consolidated Space Communication Network, to be operated by JPL, will be responsible for all ground tracking support for Deep Space Missions including high earth-orbital missions. It will NOT support low earth-orbital spacecraft which will be supported exclusively by the TDRSS. The decision to consolidate resulted from a study performed by the Networks Planning Working Group, which was established by the NASA Office of Space Tracking and Data Systems (OSTDS) in 1979. The working group membership consisted of representatives from OSTDS, the Goddard Space Flight Center (GSFC), the Jet Propulsion Laboratory (JPL), the Spanish Instituto Nacional de Tecnica Aeroespacial (INTA), and the Australian Department of Science and Environment (DSE). This study is concentrated on the capabilities, requirements and costs of the ground segment of the NASA Tracking Networks.

There were three basic drivers for the study effort. First, the early-to-mid eighties will be a period of lowered tracking activity for all space missions. Second, the early eighties will see the advent of the TDRSS which will carry the majority of the tracking load for earth-orbital spacecraft, including the low-altitude spacecraft. Third, the

increased activity in space during the second half of the eighties. To prepare for this increased load, it is appropriate to modify and reconfigure the Ground Tracking Network(s) now, for more cost-effective operation later. Figure 1 shows the present day (1980) locations of the antennas to be colocated. All other GSTDN sites will be closed after the TDRSS becomes operational.

Both the 64-meter and 34-meter antennas at each DSN complex will be used to track planetary and interplanetary spacecraft. The colocated GSTDN 9-meter antennas will be converted into a subnet to support future high earth-orbital spacecraft. Signal Processing Center (SPC) equipment should be interchangeable between planetary and high earth-orbital links. Figure 2 is an overview of the Consolidated Space Communication Network. The antennas and their associated front-end area operate in an unattended mode for all normal tracking.

The SPC will contain the centralized monitor and control equipment, telemetry demodulation, command processing equipment, frequency and timing, receiver, exciter, radio science, and communication equipment.

All manual control points for the communication complex will reside in the monitor and control equipment in the SPC. Each communication link will be supervised through a dedicated control console with all consoles centrally located in the SPC. Equipment configurations are to be such that signal combining, telemetry signal detection, and telemetry and command processing will be normally dedicated to a specific link, but can be switched for mutual backup. All antennas and front-end area subsystems which are arrayed together for a communications link will be supervised through the control console for that link. Figure 3 shows a view of a typical complex after reconfiguration.

The frequency and timing requirements are being driven by two factors. First, the impending consolidation of DSN with the colocated GSTDN is placing new requirements on the existing FTS. These requirements fall primarily into the areas of increased distribution capacity and capability, the need for centralized monitor and control of the frequency and timing equipment, and finally the need to provide time offsets (under operator control) to selected users for the purpose of simulating upcoming tracking events for training purposes. The second factor driving the requirements to develop new frequency and timing equipment is the need to replace aging equipment. The present complement of equipment at both GSTDN and DSN stations are antiquated, much of it having been implemented in the nineteen sixties.

The approach that has been followed is to take the best equipment available in either network and to design the remainder. In general, the FTS can be thought of as a series arrangement of functions as shown in Figure 4.

Sinusoidal reference generation and distribution functions will be supported by existing equipment. GSTDN equipment will be used to generate and distribute epoch time and timing pulses. The distribution capacity function, the monitor and control function, and simulation time will require new equipment.

Consolidation of the network will have a significant impact on FTS requirements. Distribution of sinusoidal reference frequency is presently made to all users in the control room and antenna. However, timing signals are a different matter. Present distribution capability of timing signals only extends to users in the control room where computers are located. With the implementation of the NCP configuration, the distribution requirements change in two ways; first, there will be more users in the SPC than currently served by the 64-meter control room FTS. Secondly, there will now be a need to provide signals to remote front-end area locations.

Coincident with implementation, the DSN will replace the monitor processors which do not have the capacity to accommodate the increased load. Implementation of monitor and control equipment will provide centralized operator capability. Additionally, the design is based upon unattended front-end areas. The ramifications of these monitor and control changes to frequency and timing is that (1) the new equipment planned for the front-end area must be unattended, and (2) the frequency and timing equipment in the SPC must have a single, digital, monitor, and control interface for the central monitor and control processor.

Simulation time code generation and distribution is another major area of change being imposed upon the frequency and timing equipment. For testing prior to critical tracking events such as encounters or spacecraft maneuvers, and for training of personnel, the FTS generates and distributes a time code that is offset (by operator command) from real time. Traditionally, the DSN has been able to offset time for all users at a station. With a Consolidated Network, that will not be possible. It will be necessary to provide selectable time (real or simulated) separately to each user. The central link operator will select, for each assembly, which time epoch to use.

FREQUENCY AND TIMING FUNCTIONAL REQUIREMENTS

In order to support the frequency and timing functions of the Consolidated Network, certain complex and network level functions must be satisfied. These functions arise out of the globally distributed nature of the FTS, the requirement for complex time synchronization, complex frequency and timing distribution, and the discipline required for maintenance of time and frequency performance records. Figure 5 is a hierarchical input-output chart depicting the FTS interfaces and the functions that serve the DSN.

Knowledge of the time offset of the DSN relative to the national standards at the National Bureau of Standards (NBS) is presently obtained by traveling clock visits from DSS-14 (Goldstone 64-meter antenna). DSS-14 serves as the DSN master frequency standard and clock and the other stations are synchronized to it. Future plans assume that this function will be performed via a Global Positioning Satellite (GPS) System with GPS time synchronization ground based receivers at both DSS-14 and NBS in Boulder, Colorado. The time offset of the DSN master frequency standard relative to USNO/NBS is maintained within 50 microseconds. Knowledge of this offset is maintained within 5 microseconds. This requirement is based upon navigation accuracy needs and stems from the need to couple ranging, doppler and VLBI measurements to the earth platform.

The measurement of frequency and time offset of each complex master standard relative to the Network Master Standard at Goldstone is achieved by a variety of techniques. Typical techniques are Very Long Baseline Interferometer (VLBI), traveling clock visits, LORAN-C time synchronization (Spain), and TV pulse time synchronization (Australia). With the inception of the Global Positioning Satellite (GPS) System and the implementation of DSN GPS time sync receivers, all but the VLBI technique will be severely curtailed. VLBI plus LORAN-C and TV sync methods are used, along with time service bulletins to provide an independent correlation of the measurements. The time offset at each complex is maintained to within 50 microseconds of the Goldstone complex and knowledge of time offset is required to be within 10 microseconds. Knowledge of the frequency offset of the frequency standard at one complex relative to the other complexes is to be within 3 parts in 10^{13} . Frequency standard errors translate into apparent spacecraft positional errors when making navigational measurements using two-station techniques such as VLBI or downlink one-way ranging. Time offset is critical to the planetary ranging methods used by the DSN.

Within each complex, there are several physically separated frequency standards and clocks. In the Network Consolidation era, most of these will be relocated to the central SPC. However, at Goldstone one

station, a 34-meter transmit-receive facility will remain physically remote from the SPC and will, therefore, still retain its stand alone frequency standard and clock. For synchronization of that station, a one pulse per second signal will be transmitted from the complex master via the area microwave system. The transmission modes are of a known and stable time delay. Time synchronization will be maintained within 50 microseconds of the complex master and knowledge of time offset will be within 3 microseconds. Knowledge of frequency offset is not as critical as for complex-to-complex offset since this station is not involved in dual station navigation measurements. Therefore, the knowledge of the frequency offset will be within 1 part in 10^{11} .

Generation and distribution of reference frequencies, timing pulses, and epoch time codes to system users in each SPC, FEA, Antenna Area and Network Operations Control Center (NOCC) is the primary purpose of the frequency and timing equipment. The sinusoidal reference frequencies, timing pulses, and epoch time codes that are generated at the complex master FTS for distribution to frequency and timing users are shown in Figure 6. Table 1 depicts the Allan variance stability requirements for reference frequencies within a complex.

The NOCC, located at JPL, Pasadena, California, requires timing pulses and epoch time codes (1 p/s, 10 p/s; 30-bit parallel BCD, 30-bit parallel binary and 36-bit serial NASA time code). The FTS presently installed at NOCC will continue to be utilized. Time synchronization is traceable to NBS/USNO through the JPL standards laboratory.

Reliability of 99.9 percent at the three complexes will be achieved with the implementation of a second Hydrogen Maser frequency standard and an upgraded Triple Redundant Timing System (TRTS) at each Network Consolidation complex. This level of reliability is based upon the reliability requirements for telemetry and tracking data and an understanding of system design in which frequency and timing references are a prerequisite to valid data.

Validation, recording, and publishing of the performance of frequency and time parameters including configuration and synchronization is an extremely important aspect of any timing system. Performance recording of reference and epoch time signals are often used as a yardstick for DSN measurements. In some applications, uncertainties in reference frequency or epoch time can be translated into measurement errors. Consequently, the stability requirements of the references and the calibration of epoch time requires accurate measurements (validation) and rigorous record maintenance. To accomplish these functions, a performance measuring capability, sufficient to ascertain functional operability, will be required. It is planned that the measurements of time and frequency stability (Allan variance) will be an automated function implemented within the Frequency and Timing Monitor and Control

System at each station. The time-variant configuration as well as alarm status will also be monitored and recorded at each station.

Network level monitoring and performance analysis will be accomplished in a semi-automated mode by the Network Operations and Analysis (NOA) Section at JPL. This NOA Section will receive reports from each station tabulating stability performance, configuration, and the results of station level offset measurements such as LORAN-C, TV sync pulse, and traveling clock visits. Additionally, the analysts will receive measurement results from VLBI data. An analysis of these data will then culminate in a periodic (monthly) report on station stability performance, complex-to-complex time and frequency offset and an analysis of any anomalous behavior.

Figure 7 is a simplified flow chart showing the data gathering process for frequency and timing performance analysis. VLBI time synchronization measurements are performed approximately on seven day centers. Upon receipt of the VLBI measurement data at a complex, the data is converted to digital form and transmitted to the VLBI Processor Subsystem at the NOCC. After processing, the data is made available for analysis at the Network Operations and Analysis (NOA) Section. Complex FTS performance parameters are data linked to the NOCC Monitor and Control (NMC) Subsystem from the Complex Monitor and Control Console (CMC). The NMC provides complex FTS monitor and status reports to the NOA. FTS monitor and status reports and the VLBI correlated data are compiled and analyzed as to time and frequency offsets between complexes and for complex master frequency standards and clock behavior.

FREQUENCY AND TIMING FUNCTIONAL DESIGN

Reference Distribution

The frequency and timing functional design is still evolving and it will continue to change as the NCP design solidifies. Complicating the process is the fact that frequency and timing signals are required to be one of the first elements of the system to become operational. The present high level block diagram for frequency and timing in the Network Consolidated era is shown in Figure 8.

The frequency and timing design is based upon the existing DSN complex master frequency standards and sinusoidal reference generators. Located at each SPC, the complex master frequency standard will consist of two Hydrogen Masers backed by two Cesium Beam Frequency Standards. These standards, which are located in an environmentally controlled area, are provided with an uninterruptible power source for possible emergencies. Switching provided in the sinusoidal reference generator allows selection of any of the four standards as the input for the complex. Switching from standard-to-standard may be

by manual operator command but, in the event of frequency standard failure, the standards are switched automatically.

Sinusoidal signals not available from the frequency standards are synthesized and distribution amplifiers provided in sufficient quantities to meet all users needs in the SPC. The amount of equipment resident in the SPC will be greater than now supported by the DSN reference generators. One reference generator will have to meet the needs of equipment that is now supported by individual reference generators at standalone stations. The extent of the needed expansion in capability is being determined, however, it is anticipated that the quantity of new distribution amplifiers will perhaps double.

Reference frequency distribution is not the only capability that will have to expand in the NCP area. Timing signal (pulses) and epoch time code distribution capability is also not adequate for a Consolidated Space Communication Network. The present planning assumes the availability of Goddard Triple Redundant Timing Systems at each complex for generation and distribution of clock signals. These timing systems are functionally identical to the timing system presently installed at the White Sands TDRSS Tracking Station.

Sinusoidal reference signals for users at the antenna areas will be distributed to the antennas either directly by uncompensated but buried cables, or by actively stabilized cables. The actively stabilized cables are used, today, only for VLBI which requires reference signals on the antenna having essentially the same stability as that of the Hydrogen Maser reference frequency standard.

Simulation Time

This function, which is not easily conveyed by a block diagram, will be achieved by a system design utilizing serial time code distribution and users individually mounted time code translators that can be individually time offset upon command. This design avoids central switching and multiple clocks while simplifying distribution. In conjunction with this effort, there will be a restriction of the types of codes available to users.

Monitor and Control

At the SPC, FTS performance parameters from the FTS master will be routed to the Complex Monitor and Control (CMC) Console via an FTS controller. The FTS performance parameters will then be data linked from the CMC to the NOCC Monitor and Control (NMC) Subsystem at JPL via the GCF, GSFC NASCOM Switch, and the JPL Central Communications terminal. Monitoring of FTS parameters via the CMC and the NMC is new for the Consolidated Space Communication Network.

Within the NOCC at JPL, the VLBI Processor Subsystem and the NOCC Monitor and Control (NMC) Subsystem perform functions for the DSN Frequency and Timing System. At the VLBI Processor Subsystem, complex VLBI time synchronization data is received over a 56 kb/s NASCOM circuit. The VLBI correlator will process the VLBI data and make it available for the Network Operations and Analysis Section (NOA).

The NMC will receive FTS parameters data linked from the complexes and will provide Monitor FTS Displays for use by the Network Operations Control Team. The NMC will also provide FTS monitor and status reports to the Network Operations and Analysis Section (NOA).

The Network Operations and Analysis Section (NOA), as a DSN supporting element, will receive complex-to-complex time and frequency offset compiled data from the VLBI correlator and FTS monitor and status reports from the NMC. The data will be analyzed as to time and frequency offsets between complexes and for complex master frequency standard and clock behavior. The NOA will advise the complexes of the results by TWX and/or written reports. The reports will also be available to the FTS Cognizant Operations Engineer (COE), Cognizant Design Engineer (CDE) and the FTS Systems Engineer (SE). The FTS services performed by the NOA are not unique to the consolidated network.

Time Synchronization

Figure 9 further illustrates in more detail, the interfacing and data flow for time synchronizing the network. Complex-to-complex time synchronization, referenced to the National Bureau of Standards, will be accomplished via Global Positioning Satellite (GPS), System and a GPS Receiving System at each complex. It is anticipated that the GPS, with its planned 18 satellites, will provide a means of synchronizing the three complexes to an accuracy of better than 50 nsec and with a time stability day-to-day of better than 10 nsec allowing an absolute frequency difference between any of the three complexes to better than 1 part in 10^{13} .

The high accuracy calibrations are achievable because of the bandwidth and signal strength the GPS offers and use of state-of-the-art atomic oscillators on-board each of the satellites. The clear access (CA) code on the L1 carrier from the GPS satellite clocks will be used. Completed procurement and implementation of GPS receivers for time synchronization at the three complexes is expected in 1984.

Complex FTS master to DSN FTS master (Goldstone) synchronization measurements are accomplished using the Very Long Baseline Interferometer (VLBI) time synchronization technique. In this technique, real-time data is sent to JPL for reduction and computation of time offset and frequency rate. The data obtained is also used for navigational

purposes. The VLBI requirements are not new to the Consolidated Space Communication Network.

COMPLEX DESIGN

The following areas within the FTS will be new for the Consolidated Space Communication Network:

- (1) Expanded distribution of reference frequencies, timing pulses, and epoch time code to support additional FEAs.
- (2) Upgraded clocks (Triple Redundant Timing System - TRTS).
- (3) Monitoring functions of FTS performance parameters.

The new TRTS will provide timing pulses and epoch time codes and a function for simulation time. The capabilities that the new clocks will have and that do not presently exist at the complexes are:

- (1) Year End: Automatic reset
- (2) Leap Year: Automatic extra day addition
- (3) Leap Second: Simple addition or subtraction of leap second
- (4) Resettability: Simple clock adjustments

Monitoring of FTS performance parameters will incorporate FTS controller equipment implemented within the FTS at the SPC. Monitor outputs of the FTS master will be routed to the controller. The controller at Goldstone will have additional inputs for monitoring of the FTS performance parameters from the standalone FTS at DSS-12. The FTS controller will route the FTS performance parameters to the DMC where measurements of time and frequency offset will be accomplished by automatic functions within the Monitor and Control System. The DSS-12 will have a monitor microprocessor which will perform the transfer functions for routing the FTS parameters to the FTS controller via the Ground Communications Facility (GCF 10).

STATUS AND SCHEDULE

The design and implementation of reference frequency and timing equipment (FTS) is paced by the first-scheduled installation completion coincident with the relocation of DSS-44 in the spring of 1983. All Signal Processing Centers, 64-meter and 34-meter Deep Space Network (DSN) antennas must be completed prior to the Voyager 2 spacecraft encounter at the planet Uranus during November 1985. The three GSTDN 26-meter antennas will be released for relocation after the TDRSS satellite is operational, currently scheduled for December 1983. The three

GSTDN 9-meter antennas are scheduled for relocation during 1986. A schedule depicting programmatic milestones, FTS equipment design and implementation and station conversion is shown in Figure 10.

CONCLUSIONS AND SUMMARY

The Consolidated Space Communication Network has been described with particular emphasis on the frequency and timing aspects of the network. System requirements have also been presented with the identification of the requirements that are different from those existing today as follows;

- (1) Increased distribution capability
- (2) Centralized monitor and control
- (3) Generation and distribution of simulated time to individual users when required.

Finally, a functional design has been presented that will meet the existing and new requirements. This design involves selection of the most modern equipment from both the DSN and the GSTDN. As the architectural design of the Consolidated Space Communications Network evolves, the FTS design will, of necessity, also change.

Table 1. Reference Frequency Stability

σ	Allan Variance $\sigma(\tau)$	
	Signal Processing Center	VLBI Antenna-Mounted Equipment
1 sec	1×10^{-12}	1×10^{-12}
10^4 sec	1×10^{-14}	1×10^{-14}
12 hours	1×10^{-14}	1×10^{-14}
10 days	2×10^{-14}	2×10^{-14}

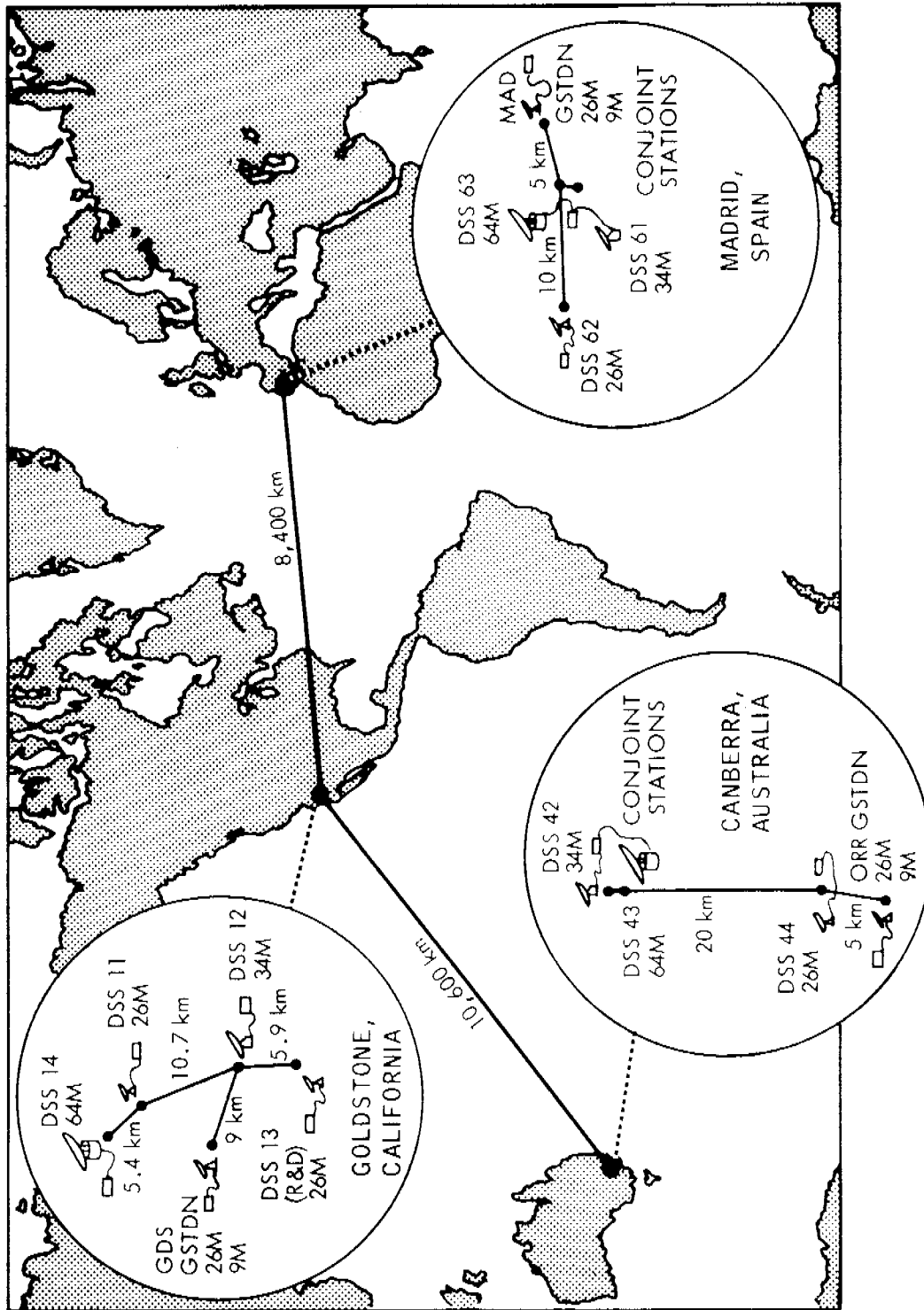

Fig. 1-Space Communication Network Complexes - 1980

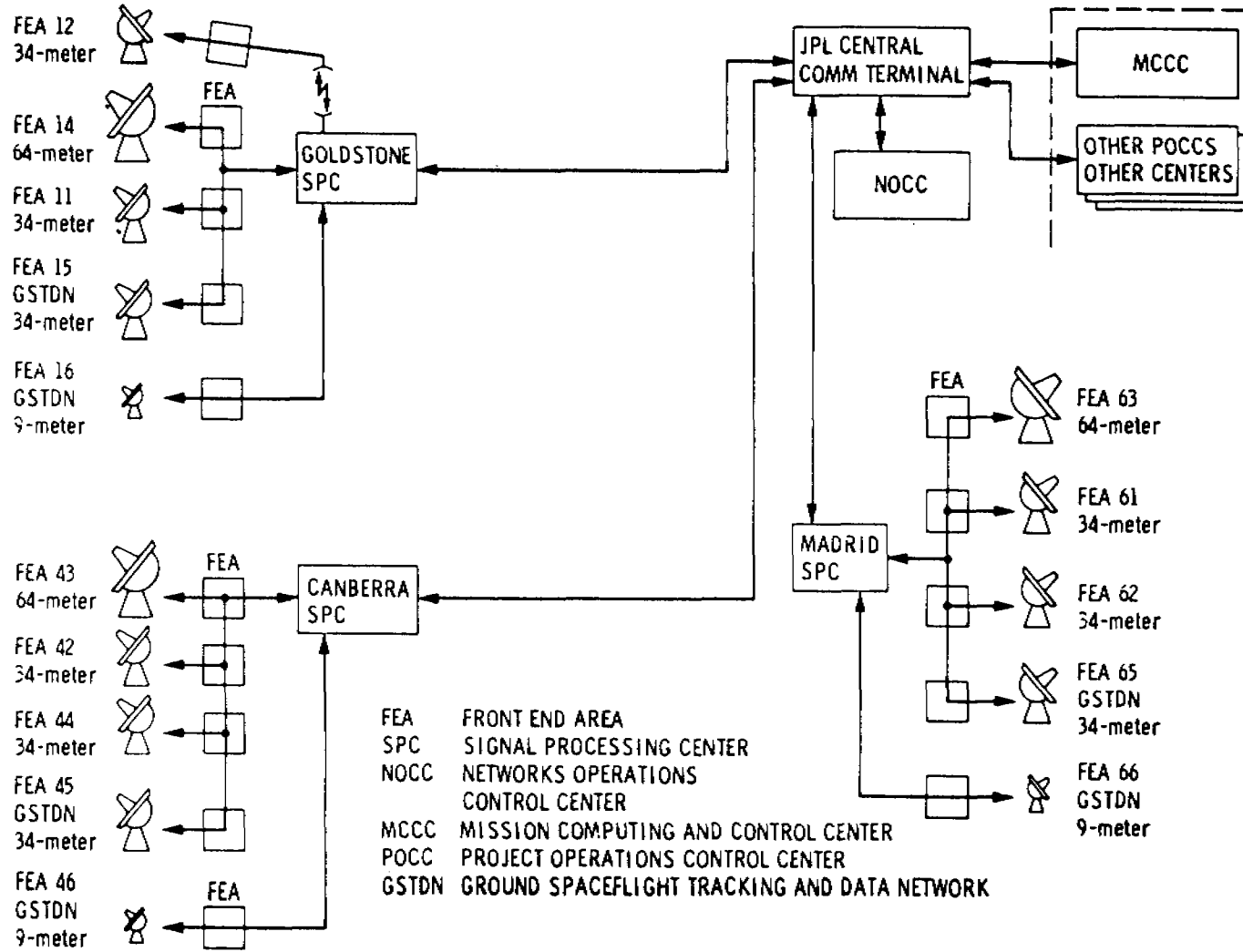

Fig. 2-Consolidated Network Configuration - 1986

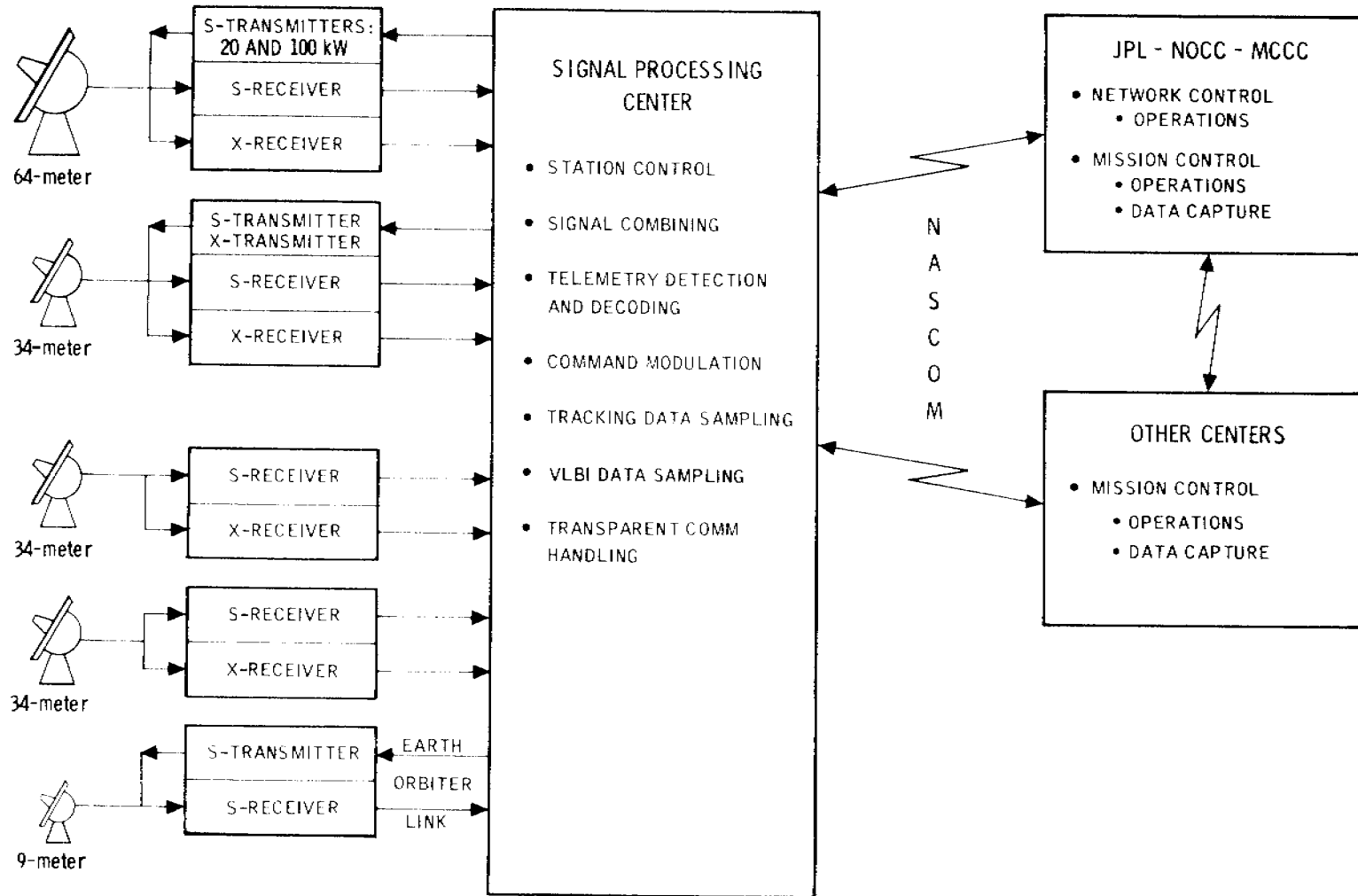

Fig. 3--Typical Complex Configuration

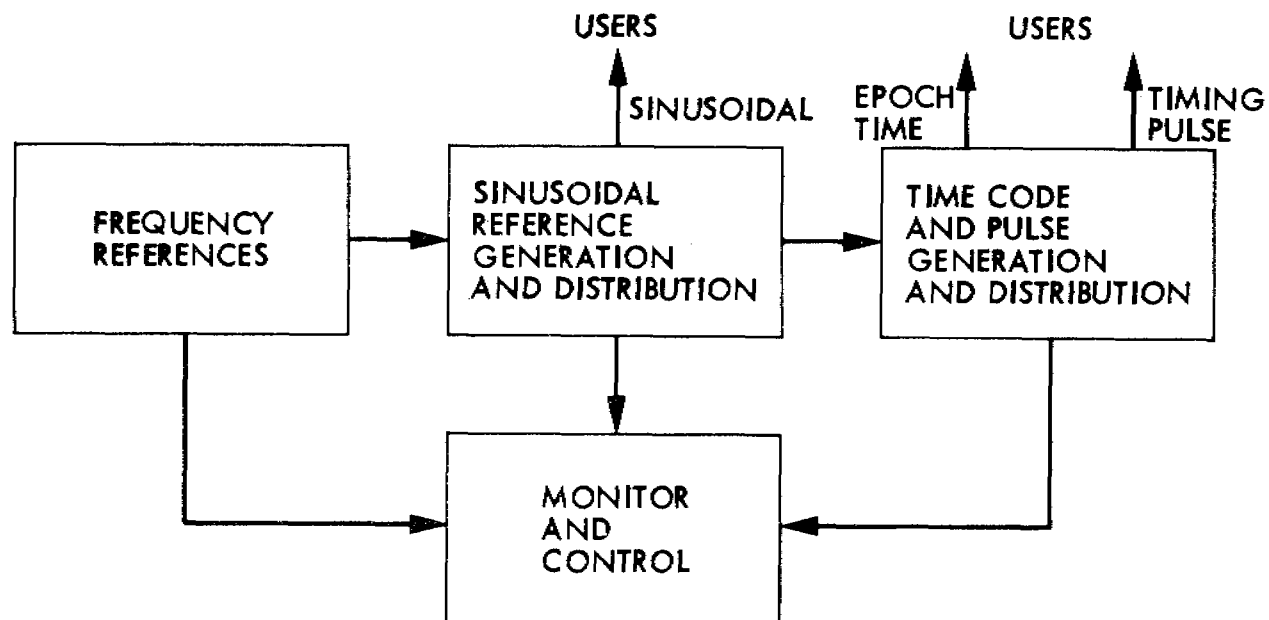

Fig. 4—Frequency and Timing System Conceptual Block Diagram

INTERFACES

USNO AND/OR NBS
UTC AND GMT

FUNCTIONS:

- MEASURE TIME OFFSETS BETWEEN DSN AND USNO AND/OR NBS
- MEASURE FREQUENCY AND TIME OFFSETS BETWEEN COMPLEXES
- PROVIDE SYNCHRONIZED TIME AND MEASURE FREQUENCY OFFSETS WITHIN EACH COMPLEX
- GENERATE AND DISTRIBUTE REFERENCE FREQUENCIES, TIMING PULSES AND EPOCH TIME CODES TO SYSTEM USERS IN EACH SPC, FEA AND NOCC WITH 99.9% AVAILABILITY
- VALIDATE, RECORD AND PUBLISH MONTHLY THE PERFORMANCE OF FREQUENCY AND TIME PARAMETERS INCLUDING CONFIGURATION AND SYNCHRONIZATION

INTERFACES

DSN FREQUENCY STABILITY
AND TIME OFFSETS
FREQUENCY AND TIMING
CORRELATED DATA

VLBI SYSTEM

REFERENCE FREQUENCIES
TIME PULSES
EPOCH TIME CODES

ALL DSN SYSTEMS

FREQUENCY AND TIMING
CORRELATED DATA AND
DSS FTS RPT (M&C)

DSN SUPPORTING ELEMENTS:
DSN NETWORK
OPERATIONS
AND ANALYSIS (NOA)

FREQUENCY AND TIMING
DATA ANALYSIS REPORTS
AND DSS FTS REPORTS

FREQUENCY AND TIMING
DATA ANALYSIS REPORTS

USERS

MONITOR
PARAMETERS

MONITOR AND
CONTROL SYSTEM

MONITOR AND
CONTROL PARAMETERS

607

Fig. 5-Functions and Interfaces Frequency and Timing System

- **SINUSOIDAL REFERENCE FREQUENCIES**
 - 0.1 MHz (SPC ONLY)
 - 1.0 MHz
 - 5.0 MHz
 - 10.0 MHz
 - 10.1 MHz (SPC ONLY)
 - 45.0 MHz
 - 50.0 MHz
 - 55.0 MHz (SPC ONLY)
 - 100.0 MHz (VLBI ONLY)
- **TIMING PULSES**
 - 1 p/s
 - 10 p/s
 - 100 p/s
 - 1k p/s (SPC ONLY)
- **EPOCH TIME CODES**
 - 36-BIT SERIAL
 - 36-BIT PARALLEL BINARY

Fig. 6-Reference Signal Types

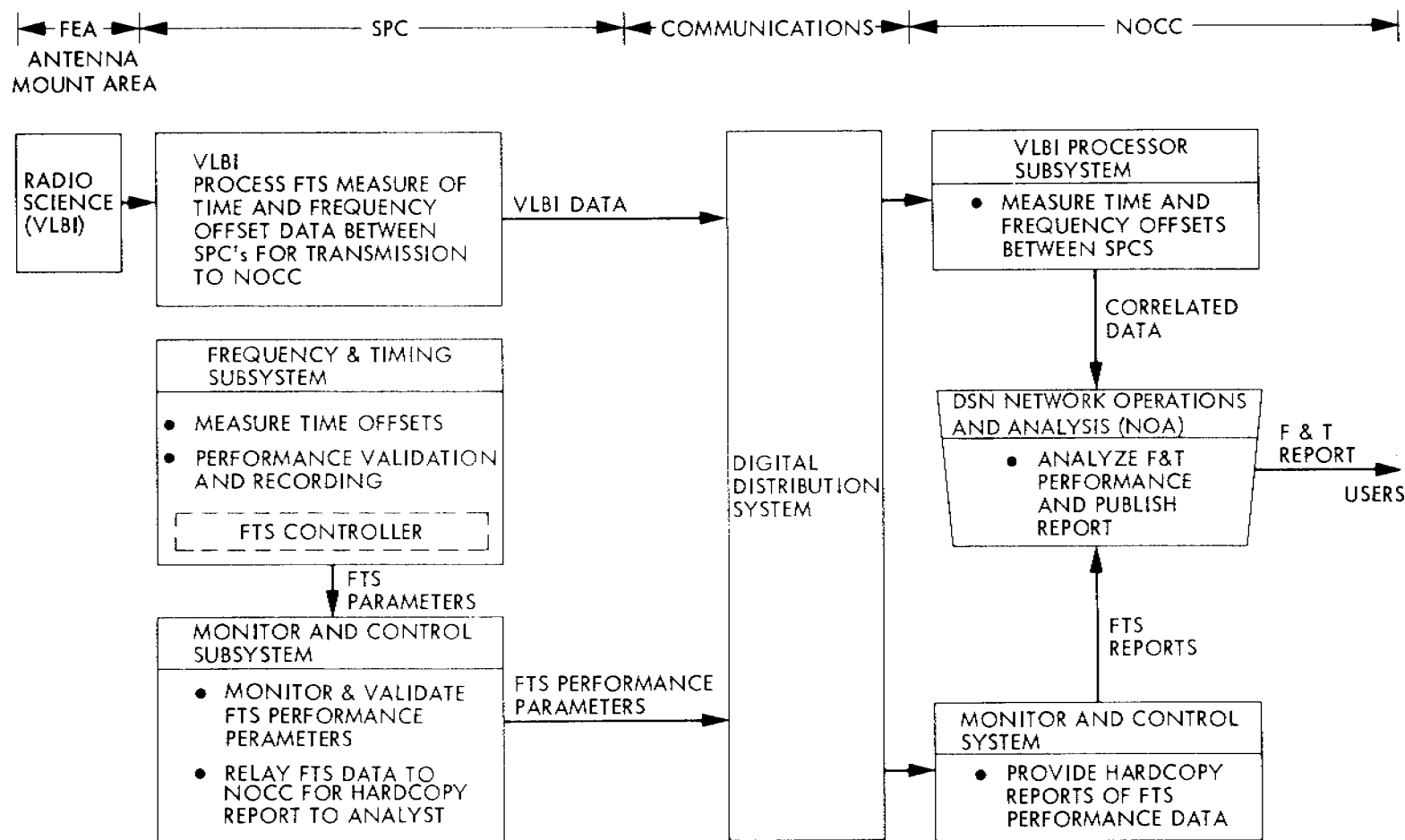

Fig. 7-Performance Analysis and Reporting

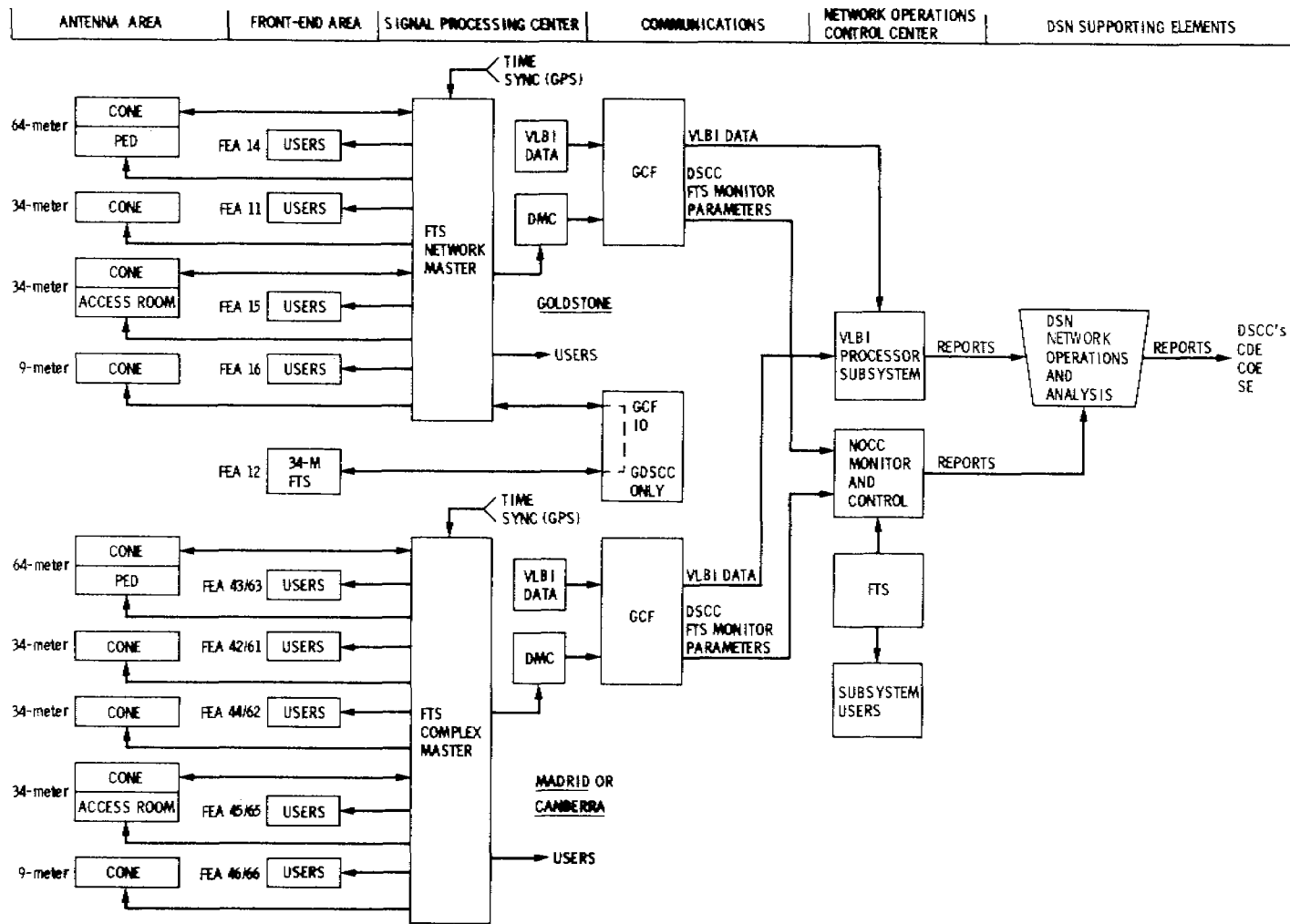

Fig. 8-Frequency and Timing System Network Level Block Diagram

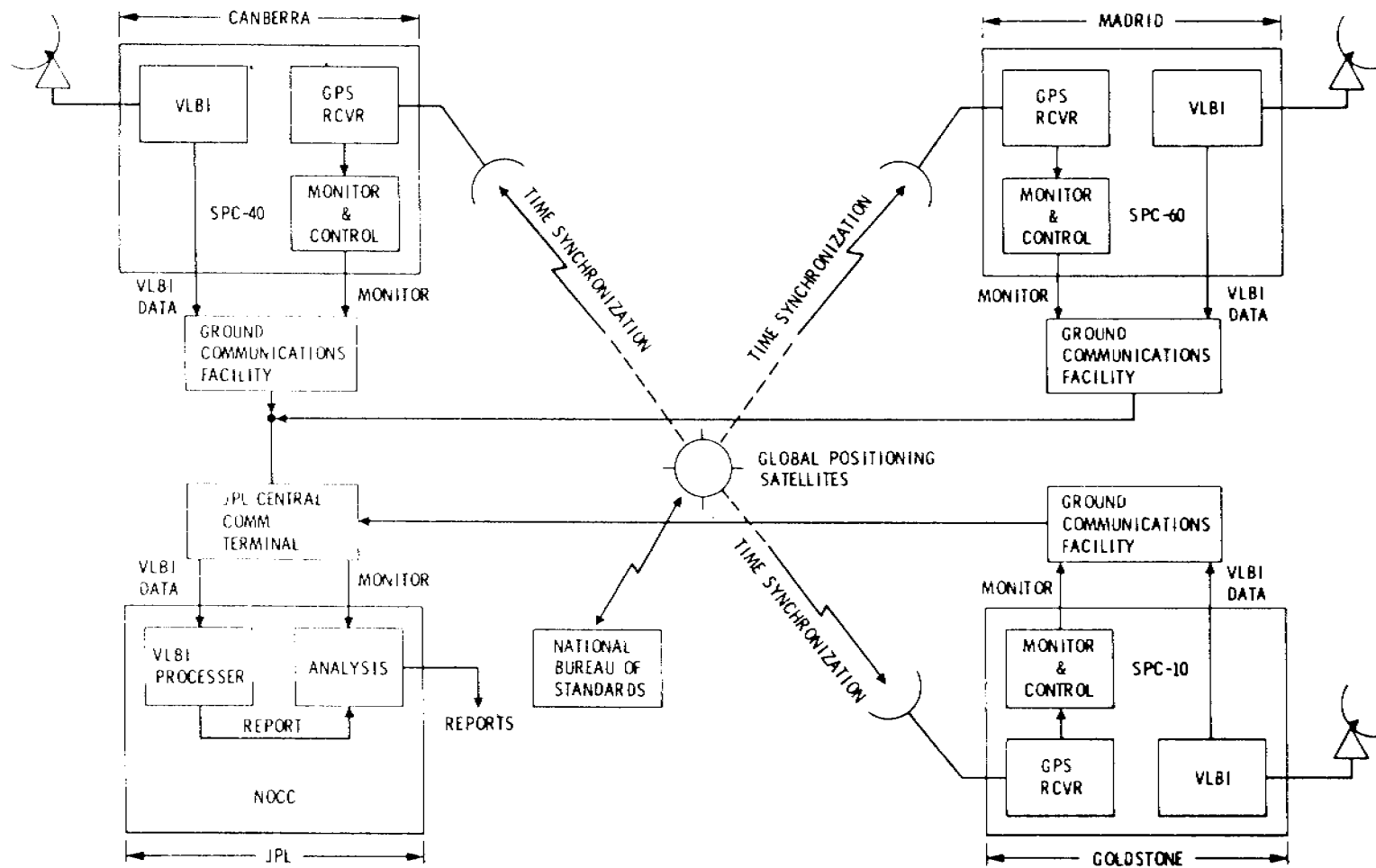

Fig. 9—Time Synchronization

	1981	1982	1983	1984	1985	1986
PROGRAMATIC MILESTONES:						
VOYAGER SATURN	△					
VOYAGER URANUS					△	
GALILEO LAUNCH				△		
TDRSS OPERATIONAL			△			
NCP-FTS MILESTONES:						
FTS SPECIFICATIONS	■△					
HARDWARE DESIGN	■	△				
PROTOTYPE	■	△				
HARDWARE FABRICATION		■	△			
FIELD INSTALLATION			■	△		
STATION CONVERSION:						
DEEP SPACE NETWORK		■	△			
GSTDN 26-m ANTENNAS				■	△	
GSTDN 9-m ANTENNAS						■△

Fig. 10-Implementation Schedule

QUESTIONS AND ANSWERS

MR. SAM WARD, The Jet Propulsion Laboratory

Dick could perhaps the synchronization to the southern hemisphere region be improved by supplying defense department mapping for the GPS receiver?

MR. COFFIN:

Well, that might be. It sounds like an interesting idea. That hadn't occurred to me Sam. It might be a good idea. Of course, you are going to ask the question after that, what about the Spanish equivalent of the Department of National Mapping I would expect.

MR. WARD:

Not necessarily.

MR. COFFIN:

Okay.

PROFESSOR LESCHIUTTA:

Yes, thank you. You mentioned the active stabilized connection between the data processing center and the antenna mount area. Would you be so kind as to explain about this? Thank you.

MR. COFFIN:

This is a stabilized link which I think, if you will see me afterwards I can put you on to a paper that will describe it in more detail but basically what it amounts to is that there is an inactive phase shifter which is part of a servo loop in which a signal is sent up to the antenna and modulates the down link. It is divided and somehow modulates the down link back down that same cable, and the signal is phase compared at the bottom and an error signal generated for this phase shifter. If you want to see me afterwards I will put you with one of the designers of that who happens to be in this room.

PROFESSOR LESCHIUTTA:

Thank you.

DR. WILLIAM WOODEN, DMAHTC

I wonder if you have given any thought to what type of receiver you were planning to install, have you given any thought to this?

MR. COFFIN:

Well I happen to know that there is work in several areas going on in GPS receivers. I think that there is some work here at Goddard and at several other locations. I believe that the National Bureau of Standards is also working on that and we have provided some funds to the National Bureau of Standards to support them in that work. And I don't know whether that will be the receiver we will finally implement, but that is certainly one possibility.